

ABUTMENT OR END BENT

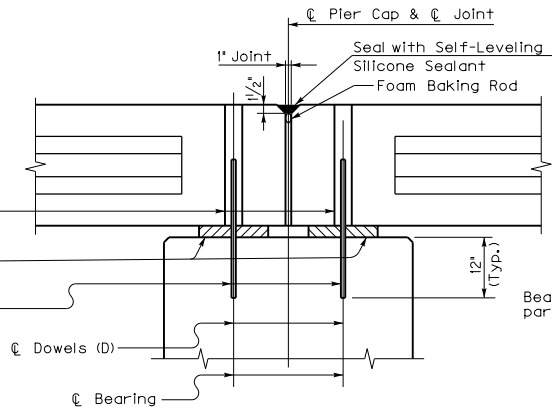

PIER OR PILE BENT

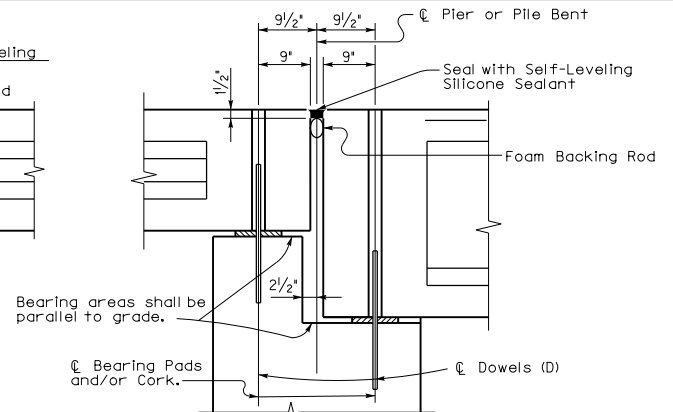

STEPPED PIER OR PILE BENT

(Showing Location & Placement of Box Beams)

TYPICAL BEARING DETAILS (NON-COMPOSITE)

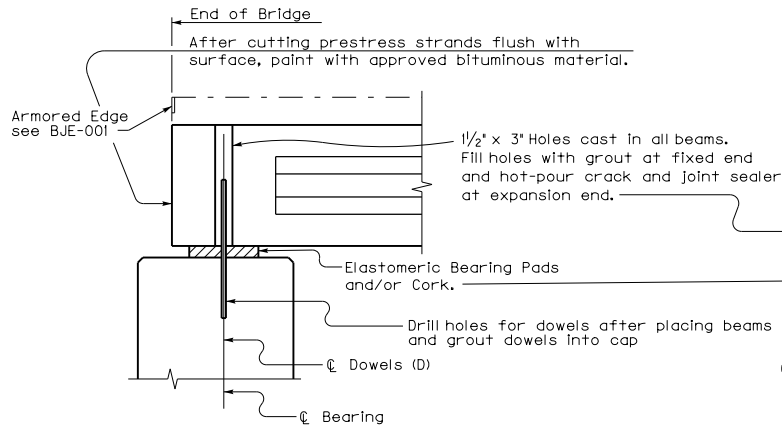

ABUTMENT OR END BENT

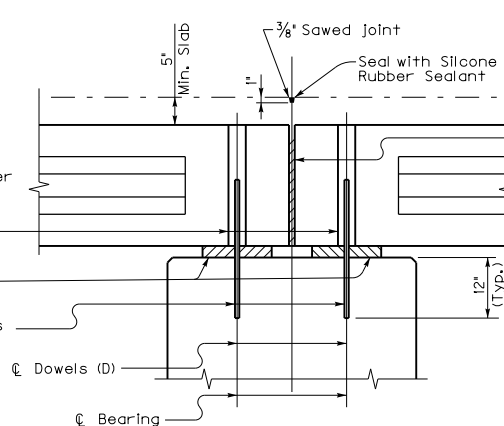

PIER OR PILE BENT

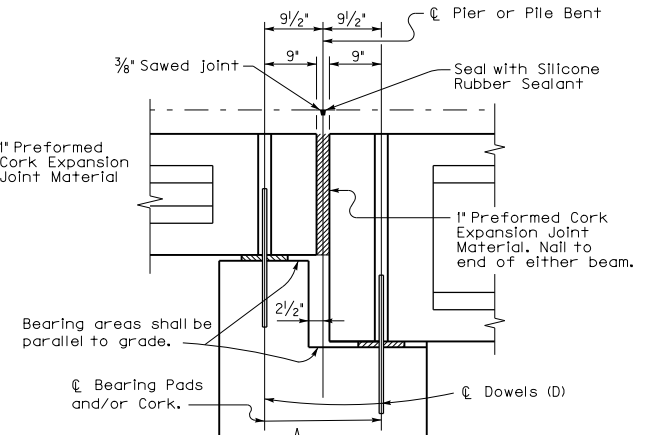

STEPPED PIER OR PILE BENT

(Showing Location & Placement of Box Beams)

TYPICAL BEARING DETAILS (COMPOSITE)

Metal shims may be required between beams of multiple span bridges to align exterior beams.

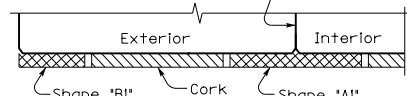

(0° Skew)

Preformed Cork Expansion Joint Material 1'-6" wide placed between Bearing Pads and beneath dowel pin holes to prevent the escape of mortar or joint sealer. Cork may be cemented to bottom of beam.

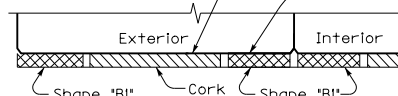

(Skewed Spans)

Metal shims (8" x 12") may be required over bearing pads or cork on skewed bridges to insure uniform bearing.

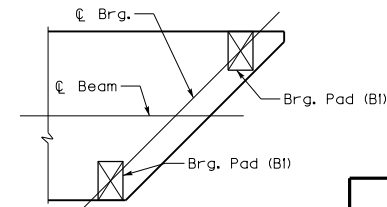

PAD PLACEMENT FOR SKEWS

Pads 'B1' are to always be placed perpendicular to beam with center of pad over bearing.

For Elastomeric Bearing Pad Details of Shapes A1 & B1, see Std. Dwg. BBP-003.

SHOWING PADS FOR BEAM TYPES B27-B42 & CB27-CB42

Use 1/2 x 1'-6" preformed cork for beam types B12-B21 & CB12-CB21 for bearing.

GENERAL NOTES

Provide metal shims conforming to ASTM A36 and galvanize in accordance with ASTM A123. As alternates, cork, polymer, or elastomer shims may be used. Include the cost of furnishing and placing these shims in the price per beam.

**KENTUCKY
DEPARTMENT OF HIGHWAYS**
**BOX BEAM
BEARING
DETAILS**

STANDARD DRAWING NO. BDP-002-03

SUBMITTED: *[Signature]* 12-02-02
DIRECTOR, DIVISION OF BRIDGE DESIGN DATE
APPROVED: *[Signature]* 12-02-02
STATE HIGHWAY ENGINEER DATE